

# Design and Performance of Vertical Axis Helical Cross-Flow Turbine Blade for Micropower Generation

Ei Ei Nwe, Dr. Aung Ko Latt

**Abstract**— This paper is intended to generate the optimum helical cross-flow turbine blade for generating the electricity. As the helical blade shape sweeps along the circumference of rotation of the turbine, some portion of the blade profile is located at the optimum angle of attack even in static or slowly rotating conditions, which allows for a more uniform starting torque that less dependent upon turbine azimuthal position. The forces acting on the blade are different by designing the blade profile. And then the pressure and velocity flow through the turbine are differing. In this paper, Hydrofoil NACA0018 and NACA 0020 are compared by using Profili Software. And then, NACA0018 is chosen based on max  $C_L/C_D$  ratio at angle of attack  $9^\circ$ . Blade design is made of wood with length (0.476m) and chord (0.1m). Steel shaft diameter and length are (0.012m) and (0.775m). Turbine test is performed in canal in front of Mandalay Technological University. According to the experimental results, it can produce 370 Watts at water velocity 2.5m/s. Finally, the pressure and velocity distribution of water on the blade are simulated by ANSYS Fluent software.

**Index Terms**— water velocity, angle of attack, blade profile, Profili Software, CFD analysis.

## I. INTRODUCTION

Nowadays, renewable energy is very important such as bio fuel energy, wind energy, solar energy, geothermal energy, biomass energy, and hydropower. Firstly, renewable energy technologies are clean energy that have a much lower environmental impact than conventional energy technologies. Hydropower has emerged as one of the alternative resource to contribute to total world energy requirements. Hydropower is generated by extracting energy from moving water using turbines. This paper is introduced to the helical turbine cross-flow turbine with very low head and low cost. Turbines do not require a dam to be built.

There are many water resources to generate electricity in Myanmar. Turbine cannot extract required power if turbine hasn't sufficient and regulated strong velocity. The turbine blade plays an important role to capture the water energy efficiently and effectively in local situations.

The flowing water possesses kinetic energy and strikes the water turbine blades. From this action some of kinetic energy are loss and transmit to useful rotational or mechanical energy of water turbine shaft. Electrical energy is converted from this mechanical energy of shaft by coupling with

generator. Therefore water turbine blade is an energy converter.

Researchers designed a hydroelectric power generator to charge batteries on small water vessels. In their work, they mentioned that this product will replace devices using non-renewable fossil fuels by utilizing the helical cross-flow turbine to capture kinetic energy from moving water [10]. The two main types of lift driven vertical axis helical cross-flow turbines are compared and observed that Darrieus-type turbine can suffer from vibrations in the shaft due to torque variations, whereas helical cross-flow type ought to reduce this problem but suffer from variations in force distribution along the length of turbine blade. They show results for is effected by various other design choices, such as blade thickness, blade chamber or turbine solidity [11].

Researchers designed and manufactured a helical cross-flow turbine and analysed the flow induced stresses at free stream velocity of 3m/s and tip speed ratio of 2 [12].

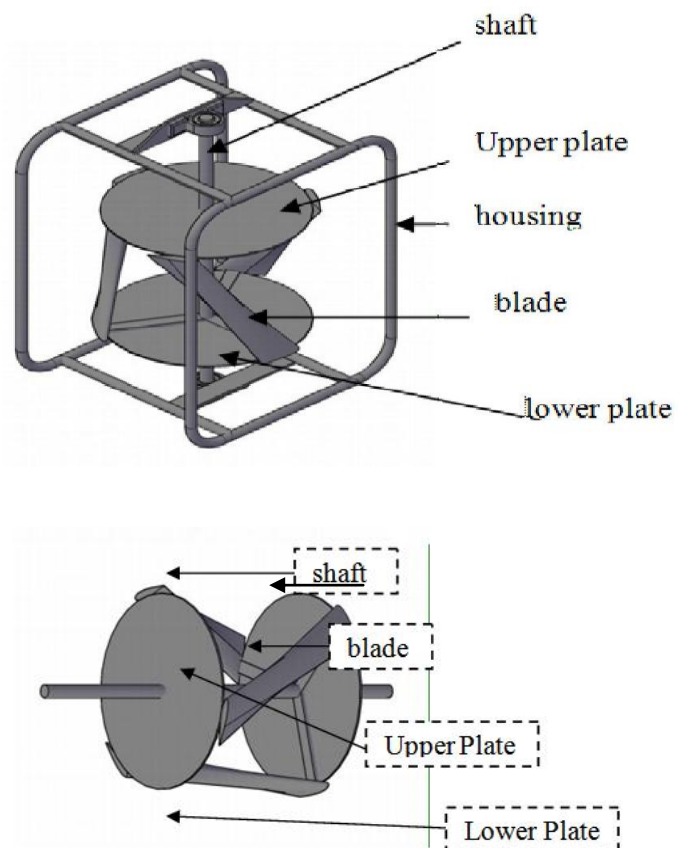

Fig 1: Turbine housing, Vertical Axis Helical Cross Flow Turbine and Horizontal Axis Helical Cross Flow Turbine

Ei Ei Nwe, Lecturer, Department of Mechanical Engineering, Mandalay Technological University, Myanmar

Dr. Aung Ko Latt, Associate Professor, Department of Mechanical Engineering, Mandalay Technological University, Myanmar

Table 1. Lift and drag coefficient ratio for NACA 0018 and NACA 0020 for Re-250000

Angle of Attack, $\alpha$	NACA 0018			NACA 0020		
	$C_L$	$C_D$	$(C_L/C_D)_{max}$	$C_L$	$C_D$	$(C_L/C_D)_{max}$
-1.0	-0.1042	0.0108	-9.6481	-0.1030	0.0116	-8.8793
0.0	0.0000	0.0108	0.0000	0.0000	0.0115	0.0000
1.0	0.1043	0.0108	9.6574	0.1031	0.0116	8.8879
2.0	0.2075	0.0111	18.6937	0.2056	0.0118	17.4237
3.0	0.3135	0.0115	27.2609	0.3075	0.0122	25.2049
4.0	0.4181	0.0122	34.2705	0.4090	0.0128	31.9531
5.0	0.5260	0.0132	39.8485	0.5097	0.0135	37.7556
6.0	0.6455	0.0144	44.8264	0.6103	0.0146	41.8014
7.0	0.7778	0.0158	49.2278	0.7244	0.0159	45.5597
8.0	0.9038	0.0175	51.6457	0.8508	0.0176	48.3409
9.0	1.0092	0.0193	52.2902	0.9694	0.0195	49.7128
10.0	1.0225	0.0208	0.0208	1.0294	0.0212	48.5566

II. METHODOLOGY

In this design, it includes of five main parts. They are

- A. Hydrofoil Selection
- B. Helical Cross Flow Turbine Design
- C. Angular velocity
- D. Chord length
- E. Lift, Drag, Tangential and Normal Force

In the design of Reynold’s number 250,000, both NACA 0018 and NACA0020 are symmetric. Both have almost same shape. But, thickness is different. So, the value of  $C_L$ ,  $C_D$ ,  $(C_L/C_D)_{max}$  of NACA 0018 is greater than NACA0020 at angle of attack  $9^\circ$ . So, NACA0018 is chosen.

A. Hydrofoil Selection

The relative velocity impinges at an angle relative to the chord line of the hydrofoil, called the angle of attack ( $\alpha$ ). This result in a pressure differential on either side of the hydrofoil, creating a net lift force. Additionally, the combination of viscous skin friction drag and pressure drag on the hydrofoil creates a net drag force on the hydrofoil. For most static hydrofoil data, the lift and drag coefficients are a function of Reynolds number (Re) and angle of attack ( $\alpha$ ).

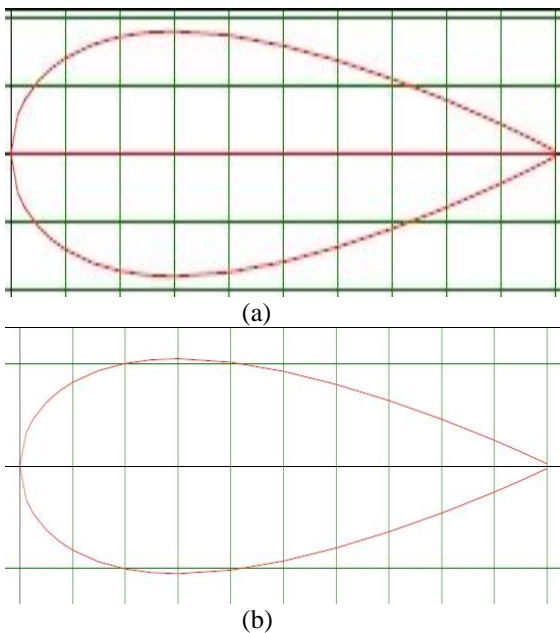

Fig 2: Comparison between (a) NACA0018 and (b) NACA 0020

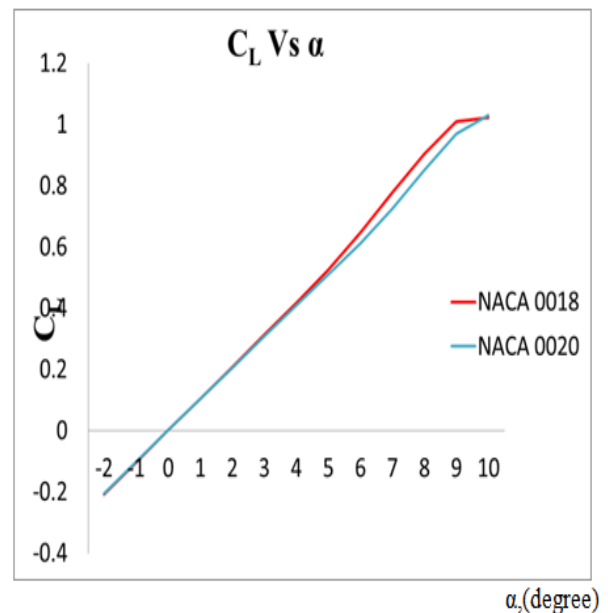

Fig 3: Coefficient of lift and angle of attack

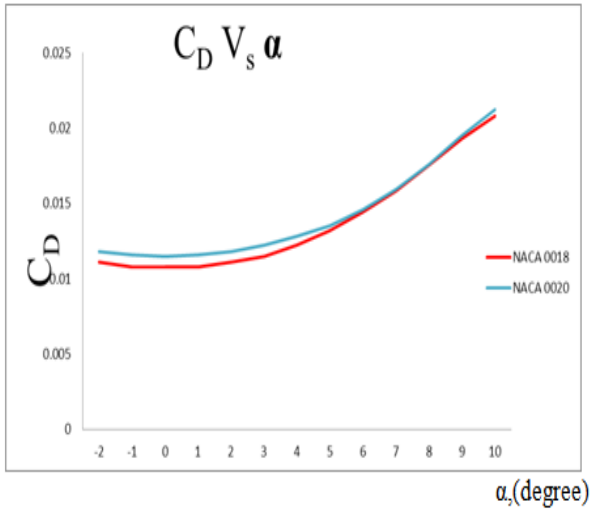

Fig 4: Coefficient of Drag and angle of attack

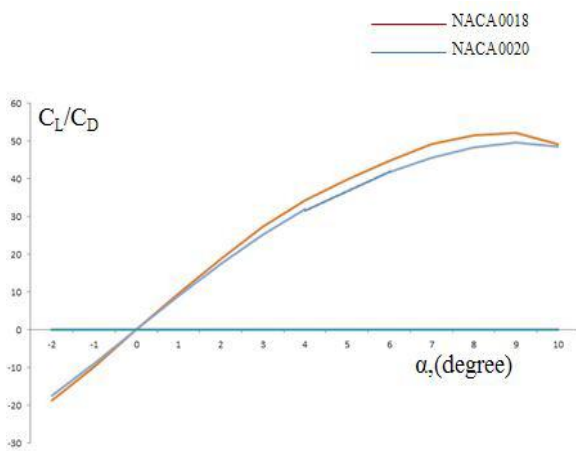

Fig 5: Coefficient of Lift and Drag Ratio and angle of attack

### B. Helical Cross-Flow Turbine Design

Specifications for helical cross-flow turbine are as follows:

$$\text{Water Power, } P_w = 0.5 \rho A V_w^3 \quad (1)$$

$$\text{Turbine Power, } P_t = 0.5 \rho C_p A V_w^3 \quad (2)$$

$$\text{Generator Output Power, } P_e = 0.5 \rho \eta_g C_p A V_w^3 \quad (3)$$

where,

$\rho$  = Water density (1000 kg/m<sup>3</sup>),

$A$  = Water area cross flow through turbine,

$V_w$  = Velocity of water,

$C_p$  =Coefficient of turbine performance

Table 2: Result Data for Water Power , Turbine Power and Electrical Power

Sr No	D (m)	h (m)	V <sub>w</sub> (m/s)	P <sub>w</sub> (W)	P <sub>t</sub> (W)	P <sub>e</sub> (W)
1	0.38	0.4191	1	80	28	24
2			1.5	269	94	80
3			2	637	223	190
4			2.5	1244	435	370
5			3	2149	752	639
6			3.5	<b>C. 3414</b>	1195	1016
7			4	5096	1784	1516
8			4.5	7256	2540	2159
9			5	9953	3484	2961
10			5.5	13248	4637	3941
11			6	17199	6020	4637
12			6.5	21868	7654	6506

Table 2 shows that water power , turbine power and electrical power are calculated by theoretically. Figure 2 shows water power, turbine power and generator power at various velocities.

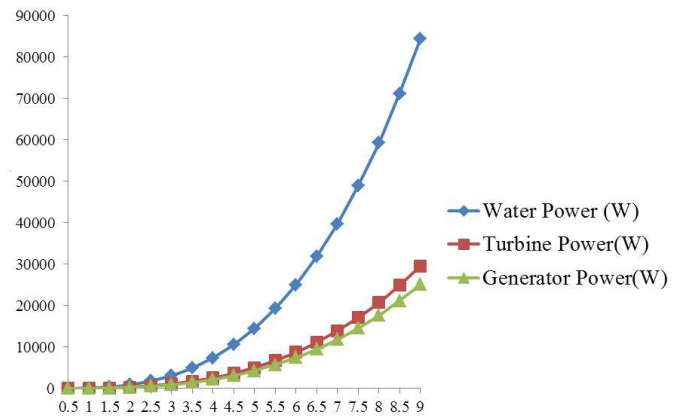

Fig 6 : Water Power, Turbine Power and Generator Power

### C. Angular Velocity

Angular velocity can be calculated by using the following equation.

$$\lambda = R\omega/v \quad (4)$$

where, R=Turbine radius

$\omega$ =Angular velocity

### D. Chord length

The chord length is calculated from the following equation.

$$c = \sigma \pi D/B \quad (5)$$

where,  $\sigma$  = solidity

$B$  = number of blades

$D$  = diameter of turbine

E. Lift, Drag, Tangential and Normal Formulation

$$\begin{aligned}
 \text{Lift Force, } F_L &= 1/2 \times C_L \times \rho \times u_{rel}^2 \times A_e \quad (6) \\
 \text{Drag Force, } F_D &= 1/2 \times C_D \times \rho \times u_{rel}^2 \times A_e \quad (7) \\
 \text{Normal Force, } F_N &= 1/2 \times C_N \times \rho \times u_{rel}^2 \times A_e \quad (8) \\
 \text{Tangential Force, } F_T &= 1/2 \times C_T \times \rho \times u_{rel}^2 \times A_e \quad (9) \\
 C_N &= C_L \cos(\alpha) + C_D \sin(\alpha) \quad (10) \\
 C_T &= C_L \sin(\alpha) - C_D \cos(\alpha) \quad (11)
 \end{aligned}$$

where,  $C_D$  = Drag coefficient,  
 $C_L$  = Lift coefficient,  
 $C_T$  = Tangential coefficient,  
 $C_N$  = Normal coefficient,  
 $u_{re}$  = relative velocity of water  
 $A_p$  = blade element platform area

Table 3: Results Data for Forces on hydrofoil

No	Description	Symbol	Value	Unit
1	Tangential coefficient	$C_T$	0.139	-
2	Normal coefficient	$C_N$	0.999	-
3	Lift Coefficient	$C_L$	1.0092	-
4	Drag Coefficient	$C_D$	0.0193	-
5	Tangential Force	$F_T$	20.59	N
6	Normal Force	$F_N$	148	N
7	Lift Force	$F_L$	149.5	N
8	Drag Force	$F_D$	2.859	N

III. NUMERICAL ANALYSIS

Numerical analysis include

- A. Modeling of hydrofoil
- B. Meshing
- C. Solving in fluent
- D. Simulation Results

A. Modeling of hydrofoil

In design modeler, hydrofoil geometry is imported from a file containing a list of vertices along the surface. The data coordinates of two design hydrofoils get from Airfoil Tools. The fluid volume with pressure far-field boundary is created as shown in Fig. The frozen surface body is constructed to generate mesh around the hydrofoil.

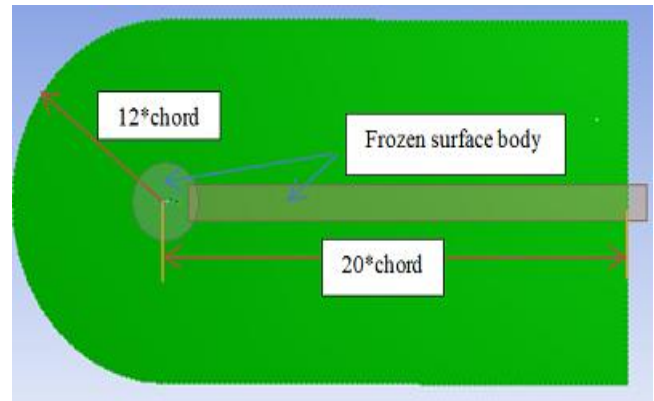

Fig. 7 Geometry of hydrofoil with boundaries

B. Meshing

The geometry from design modeler is imported to mesh. Mesh generating is important. The fine mesh provides approximately same result with experiments and takes much time. The coarse mesh has a little different with fine mesh.

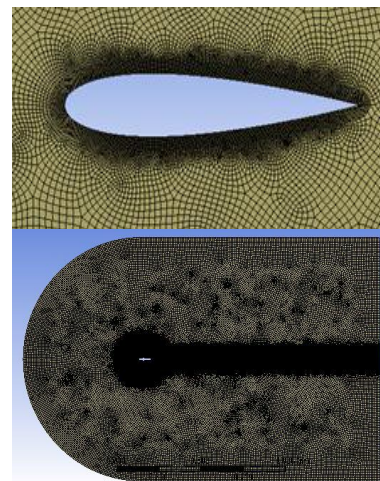

Fig. 8 Meshing of Hydrofoil

C. Solving in fluent

After meshing, fluid flow is solved based on the dimensionless parameter of Reynolds number 250000. The iterations are made 4000 time for convergence.

TABLE 4  
SPECIFICATIONS IN SOLVER

Model	Spalart-Allamarus
Solver	Density based, steady based
Inlet velocity	2.5
Chord Length	0.1
Water Density	1000

D. Simulation Results

Simulation results of pressure and velocity are as follows.



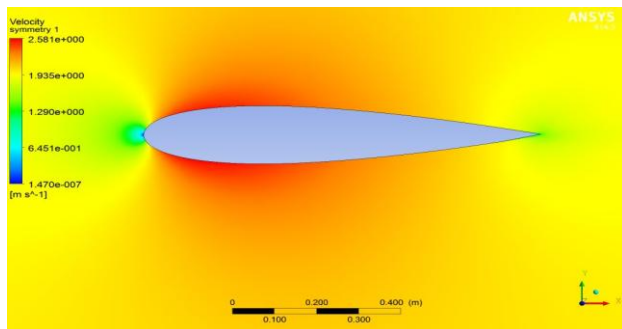

Fig: 9 Velocity Distribution

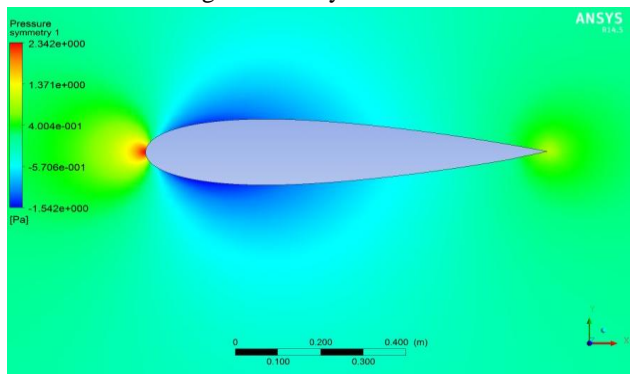

Fig 10: Pressure Distribution

### III. DISCUSSION AND EXPERIMENTAL RESULT

According to the experimental results, it can operate about 50 rpm for vertical position and about 60 rpm for horizontal position at water velocity 1.5 m/s.

TABLE 5  
EXPERIMENTAL RESULT AT VARIOUS VELOCITIES

Sr	v <sub>w</sub> (m/s)	Water Speed(rpm)		Angular Velocity(rad/s)	
		Hori zont al	Vertical	Horizon tal	Vertical
1	2.3	57	49	5.96	5.131
2	2.4	62	50	6.49	5.24
3	2.5	64	54	6.7	5.65
4	2.6	65	55	6.81	5.76
5	2.7	68	57	7.12	5.97
6	2.8	71	58	7.435	6.07

### IV. CONCLUSIONS

In this paper, by depending the water flow velocity and angle of attack, helical cross flow turbine blade profile is chosen. For a hydrofoil profile to obtain optimum performance: high stall angle, wide range of angle of attack

with corresponding low drag, high lift-to-drag ratio, high maximum lift coefficient. The forces acting on the blade are different by designing the blade profile. And also the pressure and velocity are differing. So, to obtain the required power, the maximum  $C_L/C_D$  chooses. But, helical cross flow turbine blade with NACA0018 and NACA0020 are compared with Profili Software. NACA0018 is more efficient than NACA0020. And then, NACA0018 is chosen and designed the performance of 2D hydrofoil theoretically and numerically. This paper is only intended to flow characteristics of two hydrofoils with specific angle of attack. The various angle of attack with different flow model should be carried out to valid the flow distribution over hydrofoil.

### ACKNOWLEDGEMENT

The author especially wishes to acknowledge her respective teachers of Mechanical Engineering Department, Mandalay Technological University who gave their knowledge, helps during the theoretical study and thesis paper preparation. Finally, the author wishes to extend her gratitude to her parents and family for their sacrifices, love, moral support and encouragement throughout her entire life.

### ABBREVIATIONS

Description	Symbol	Unit
Turbine Power	P <sub>t</sub>	W
Turbine radius	R	m
Angular velocity	$\omega$	rad/s
Velocity of water	v <sub>w</sub>	m/s
Turbine diameter	D	m
Water density	$\rho$	kg/m <sup>3</sup>
Turbine height	H	m
Tip Speed Ratio	$\lambda$	-
Solidity	$\sigma$	-
Power coefficient	C <sub>p</sub>	-

### REFERENCES

- [1] Alexander Gorlov, Helical Turbine and Fish Safety, August 2010.
- [2] Adam L.Niblick, Experimental and Analytical Study of Helical Cross-Flow Turbines for a Tidal Micro power Generation System 2012, University of Washington.
- [3] Dr. Michael Hinchey, Design, Fabrication and Testing of a Water Current Energy Device, April 4<sup>th</sup>,2014.
- [4] Josh Anderson, Design and Manufacture of a Cross-Flow Helical Tidal Turbine, June 14, 2011.
- [5] Nathan Willard, Efficiency Investigation of a Helical Turbine for Harvesting Wind Energy, September 2011.
- [6] Peter Bachant, Experimental Investigation of Helical Cross-Flow Axis Hydrokinetic Turbines, Including Effects of Waves and Turbulence, 2011, USA.
- [7] Sounthisack Phommachanh, Simulation and PIV Experiment of the Ducted Water Current Turbine And Extremely low Head Helical Turbine, November 9, 2012.
- [8] Kari Sarnes, Small Scale Water Current Turbines for River Applications, January 2010.
- [9] Syed Shah Khalid, Harnessing Tidal Energy Using Vertical Axis Tidal Turbine, 29 June, 2012.